

K493

Fitting Kit

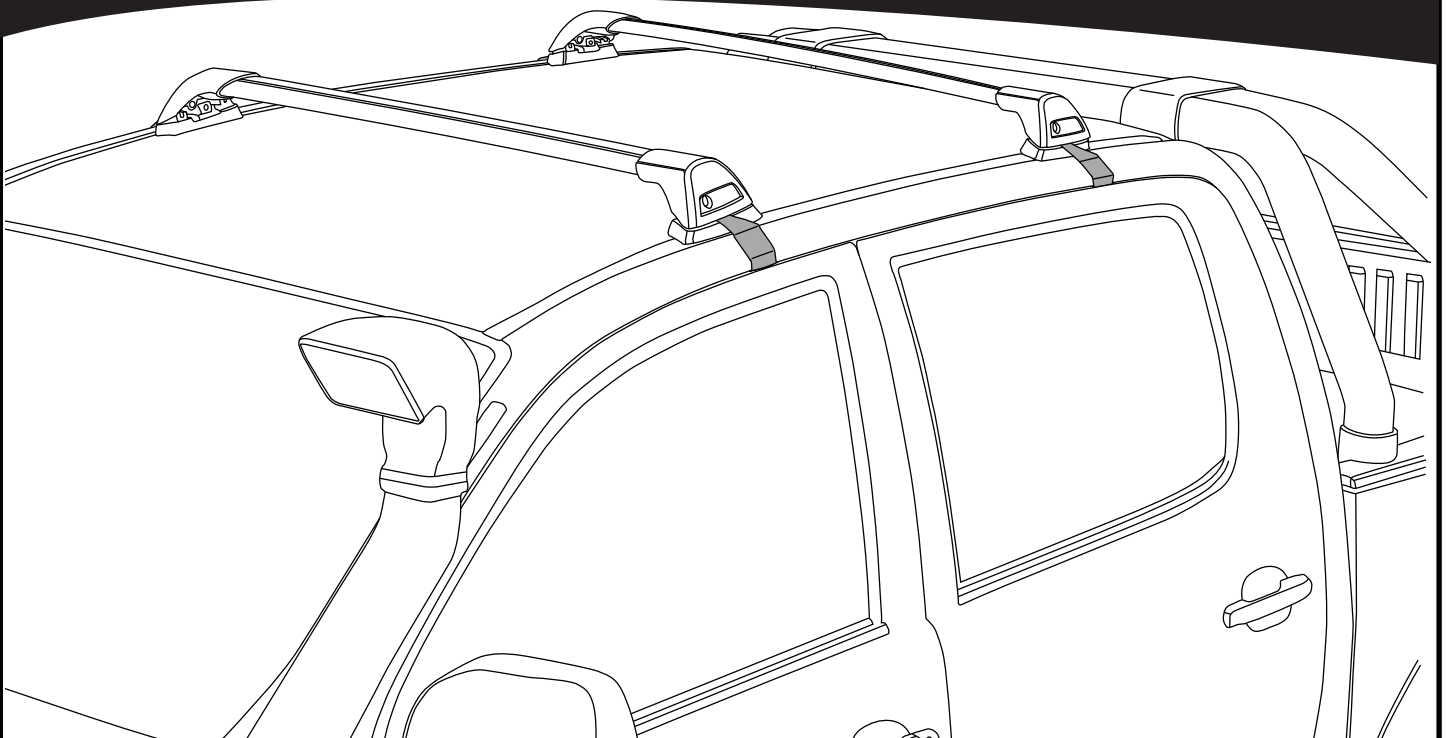

**REQUIRED • ERFORDERLICH • REQUERIDOS • OBLIGATOIRE • NØDVENDIG • NECESSÁRIO
ОБЯЗАТЕЛЬНО • OBBLIGATORIO • POTRZEBY • NEVYHNUTELNÉ • NEVYHNUTNÉ • NODIG • NÖDVÄNDIG**

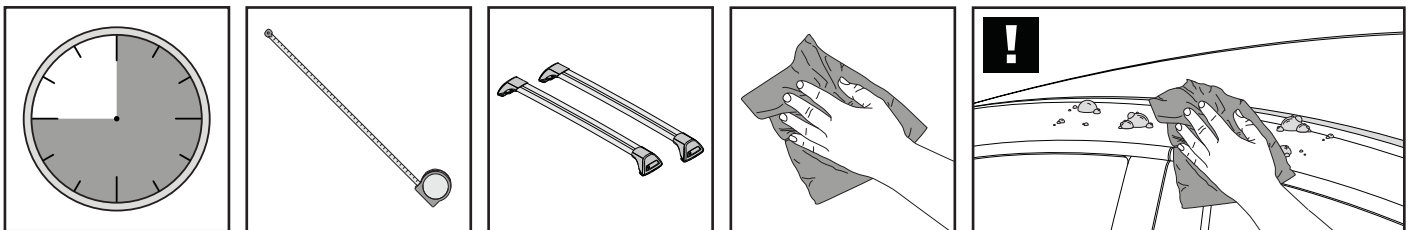

**MAXIMUM kg (lb) • MAXIMUM kg • MÁXIMO kg • MAXIMUM kg • MAKSIMALT kg • MÁXIMO kg
МАКСИМУМ кг • MASSIMO kg • MAKSIMALNEJ kg • MAXIMÁLNÍ kg • MAXIMÁLNE kg
MAXIMUM kg • MAXIMAL kg**

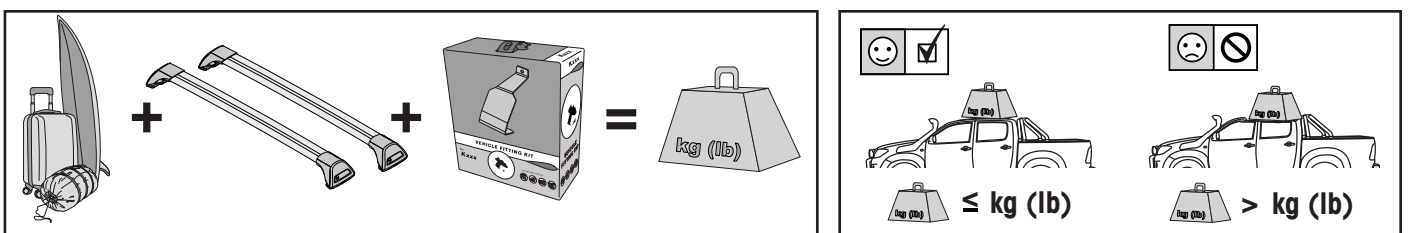

		F T P	HD
Nissan Navara D40 Double Cab, 4dr Ute 05+	CN, EU	75 kg (165 lb)	75 kg (165 lb)
Nissan Navara D40 Double Cab, 4dr Ute Nov 05-May 15	AU	75 kg (165 lb)	75 kg (165 lb)
Nissan Navara D40 Double Cab, 4dr Ute Dec 05-May 15	NZ	75 kg (165 lb)	75 kg (165 lb)
Nissan Navara D40 KingCab, 4dr Ute 05+	EU	75 kg (165 lb)	75 kg (165 lb)
Nissan Navara D40 KingCab, 4dr Ute 05-May 15	AU, NZ, ZA	75 kg (165 lb)	75 kg (165 lb)
Nissan Navara D40 Single Cab, 2dr Ute 05-15	AU, NZ	35 kg (77 lb)	35 kg (77 lb)
Nissan Pathfinder, 5dr SUV 05+	CN, EU	75 kg (165 lb)	75 kg (165 lb)

- EN** **ATTENTION: NISSAN NAVARA D40 ONLY**
Weather sealing cannot be guaranteed due to manufacturer's assembly variations.
If this is of concern please use K603 permanent mount fitting kit.
- DE** **ACHTUNG: NUR NISSAN NAVARA D40**
Die Wasserdichtigkeit kann aufgrund der Bauvarianten des Herstellers nicht garantiert werden.
Wenn dies von Bedeutung ist, verwenden Sie bitte den Bausatz K603 für die Montage der dauerhaften Halterung.
- ES** **ATENCIÓN: SÓLO PARA NISSAN NAVARA D40**
No se garantiza la impermeabilidad debido a variaciones en el ensamblaje del fabricante.
Si esto le preocupa, rogamos utilice el kit de ensamblaje de montura permanente K603.
- FR** **ATTENTION : SEULEMENT NISSAN NAVARA D40**
L'étanchéité du joint ne peut pas être garantie en raison des variations de montage du fabricant.
Si cela vous concerne, utilisez le kit de montage permanent K603.
- NO** **OBS: KUN NISSAN NAVARA D40**
Ingen garanti kan gis for værtetningen grunnet monteringsvariasjoner hos produsenten.
Hvis dette gir grunn til bekymring, bruk settet K603 for permanent montering.
- PT** **ATENÇÃO: APENAS NISSAN NAVARA D40**
O vedante de protecção contra condições climáticas não pode ser incluído na garantia devido a variações de montagem do fabricante. Se esta situação for um motivo de preocupação, utilize o kit de montagem permanente K603.
- RU** **ВНИМАНИЕ! ТОЛЬКО ДЛЯ NISSAN NAVARA D40**
Принимая во внимание особенности сборки, невозможно гарантировать защиту от атмосферных воздействий.
Если этот аспект имеет очень важное значение, используйте комплект для стационарного монтажа K603.
- IT** **ATTENZIONE: SOLO NISSAN NAVARA D40**
La tenuta dagli agenti atmosferici non può essere garantita a causa delle variazioni dei gruppi del produttore.
Se del caso utilizzare il kit di fissaggio sostegni permanenti K603.
- PL** **UWAGA: DOTYCZY WYŁĄCZNIE MODELU NISSAN NAVARA D40**
Uszczelnienie pogodowe nie jest gwarantowane ze względu na różne opcje montażowe producenta.
W razie konieczności należy użyć zestawu montażowego K603.
- CS** **UPOZORNĚNÍ: POUZE NISSAN NAVARA D40**
Přesnost těsnění nelze zaručit z důvodu různých montážních variant. Je-li to možné, použijte montážní kit K603.
- SK** **UPOZORNENIE: LEN NISSAN NAVARA D40**
Z dôvodu rozdielov výrobcu pri montáži nie je možné zaručiť utesnenie proti vplyvu počasia.
Ak ide o tento prípad, použite montážnu sadu pre trvalé upevnenie K603.
- NL** **ATTENTIE: ALLEEN VOOR NISSAN NAVARA D40**
De water afdichting kan niet worden gegarandeerd vanwege de assemblage varieties van de fabrikant. Als dit van belang is gebruikt u dan montagekit K603 met permanente montage.
- SV** **OBS: ENDAST NISSAN NAVARA D40**
Vädertätningen kan inte garanteras på grund av tillverkarens monteringsvariationer.
Om detta är ett problem ska den permanenta monteringsatsen K603 användas.

**CONTENTS • INHALT • CONTENIDO • CONTENU • INNHOLD • CONTEÚDO • СОДЕРЖАНИЕ • CONTENUTO
ZAWARTOŚĆ • OBSAH • OBSAH • INHOUD • INNEHÅLL**

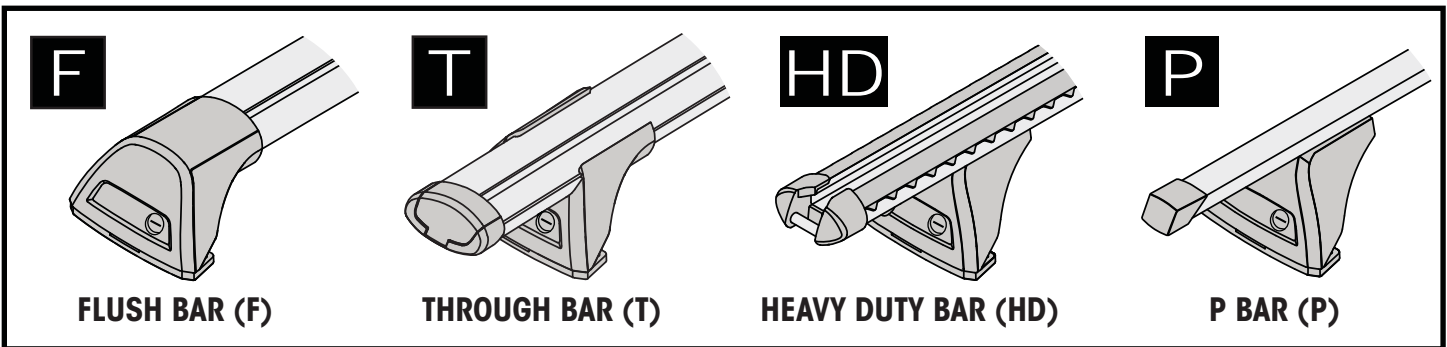
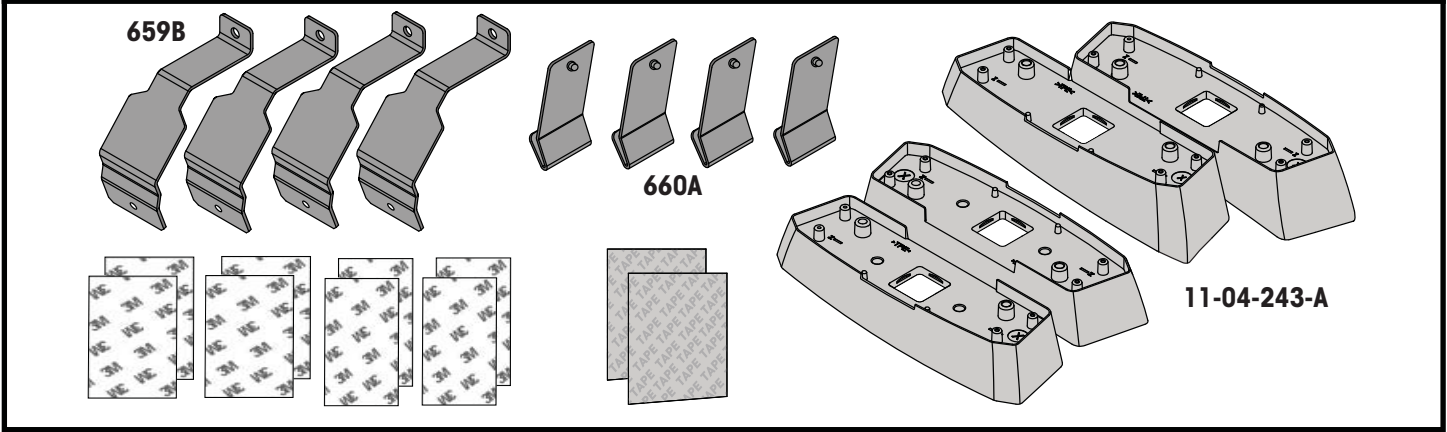

**ATTENTION • ACHTUNG • ATENCIÓN • ATTENTION • OPPMERKSOMHET • ATENÇÃO • ВНИМАНИЕ
ATTENZIONE • UWAGA • UPOZORNĚNÍ • UPOZORNENIE • LET OP • UPPMÄRSAMHET**

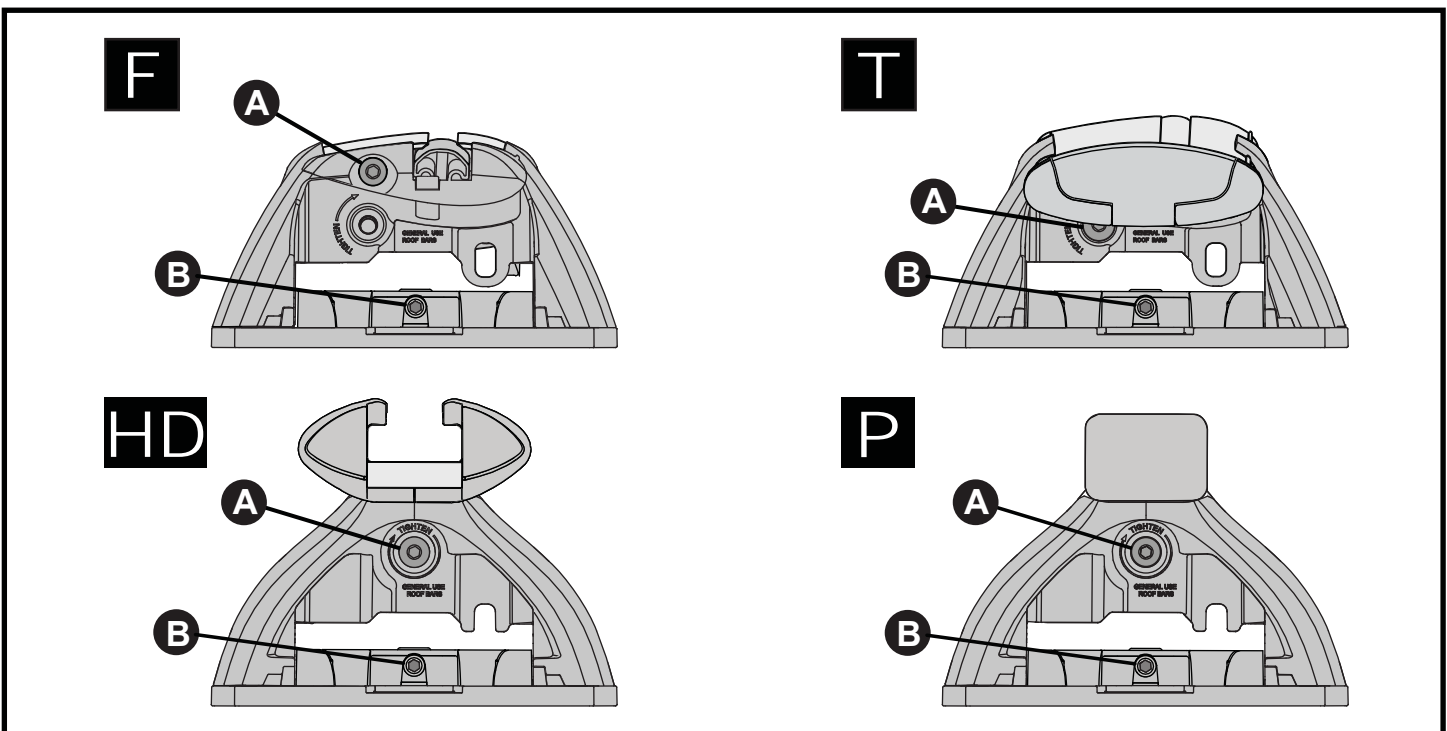
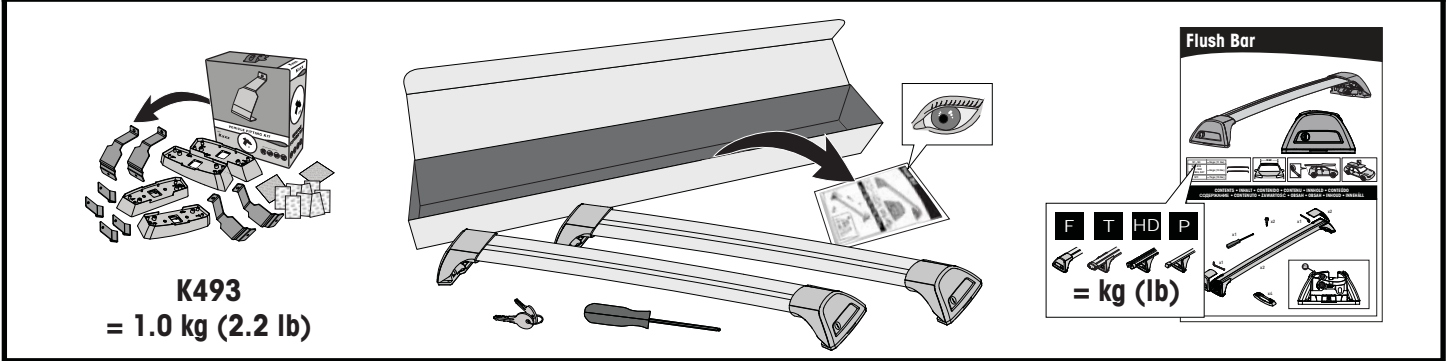

ATTENTION • ACHTUNG • ATENCIÓN • ATTENTION • OPPMERKSOMHET • ATENÇÃO • ВНИМАНИЕ
 ATTENZIONE • UWAGA • UPOZORNĚNÍ • UPOZORNENIE • LET OP • UPPMÄRKSAMHET

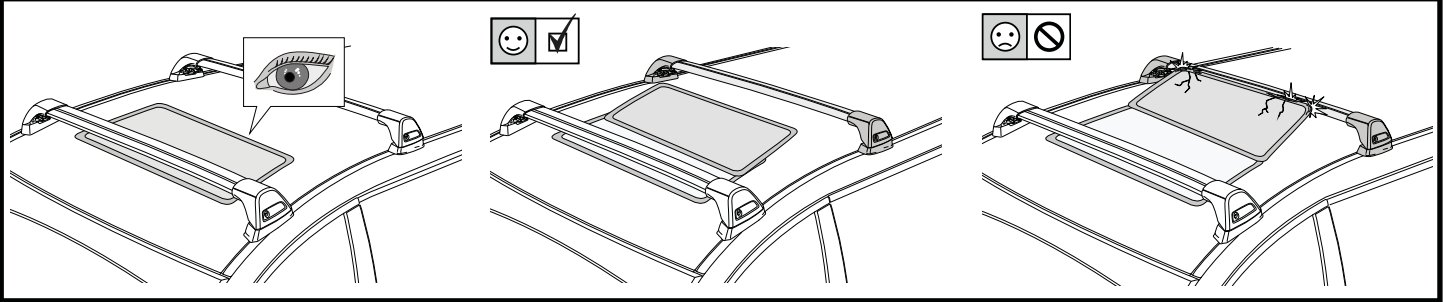

1

F

T

HD

P

x4

2

HD/P

WARNING
 LOAD PARTS MAY BE
 REDUCED FOR SOME VEHICLES.
 REFER TO FITTING KIT

01-02-237A >PA8-GF30<

F/T

x10

A

x4

3

FR = 11-04-243-A

FL = 11-04-243-A

RR = 11-04-243-A

RL = 11-04-243-A

4

FR

RR

FL

RL

x4

5

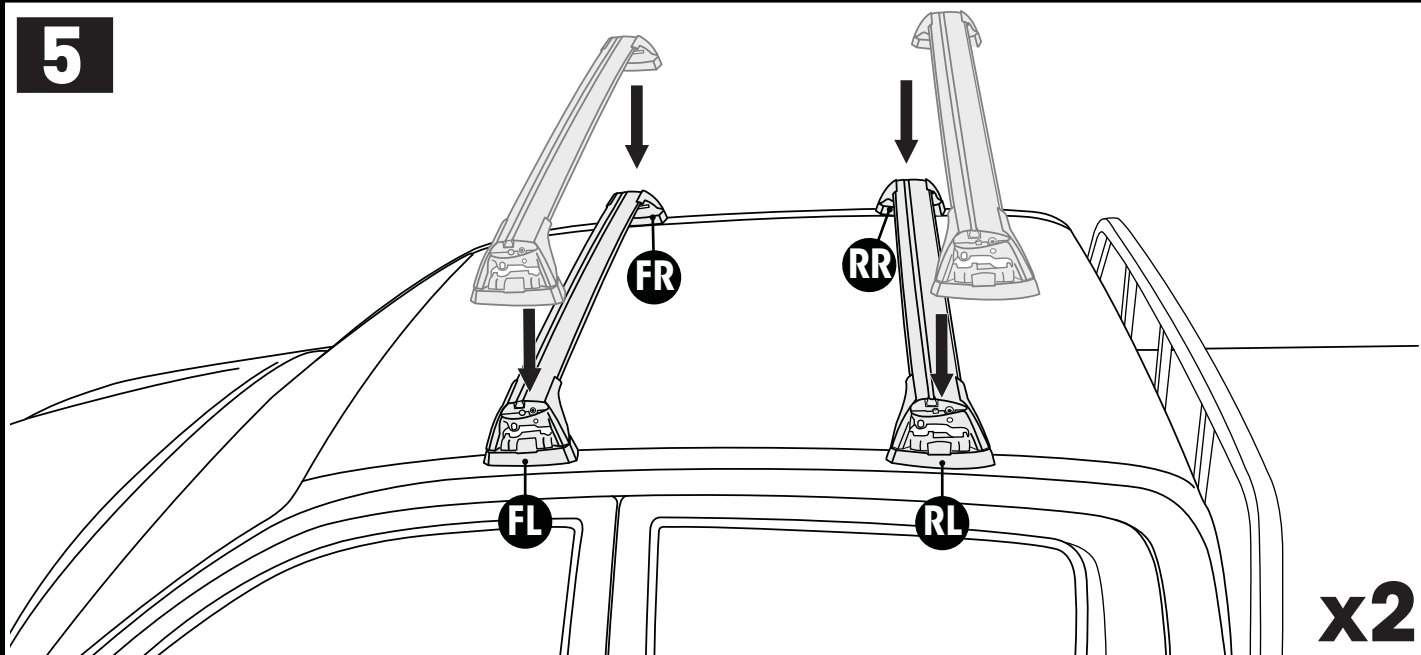

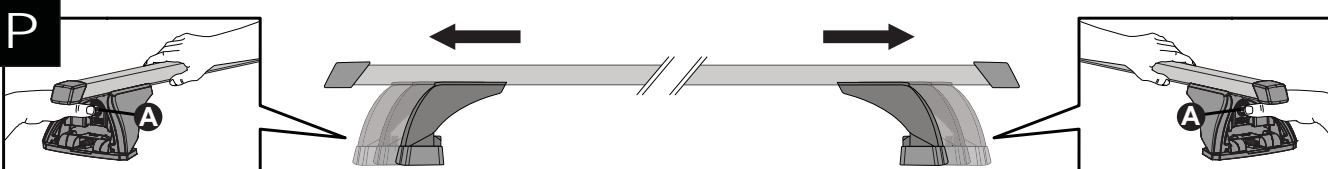
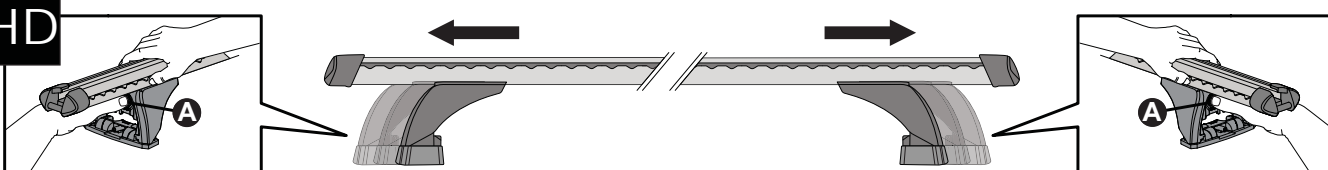
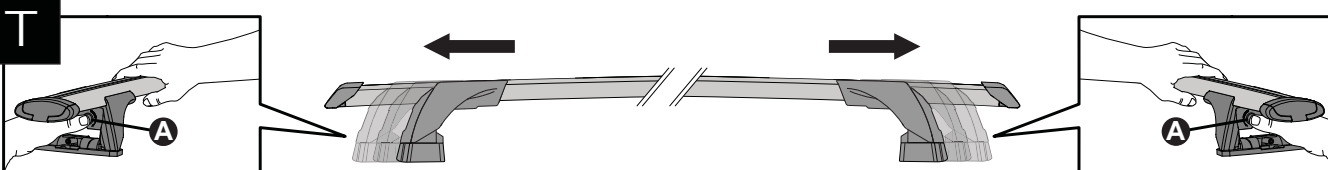
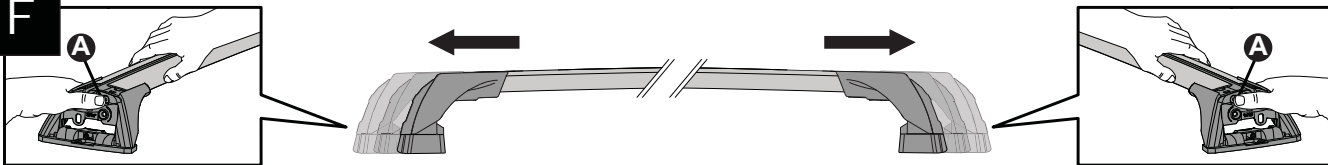
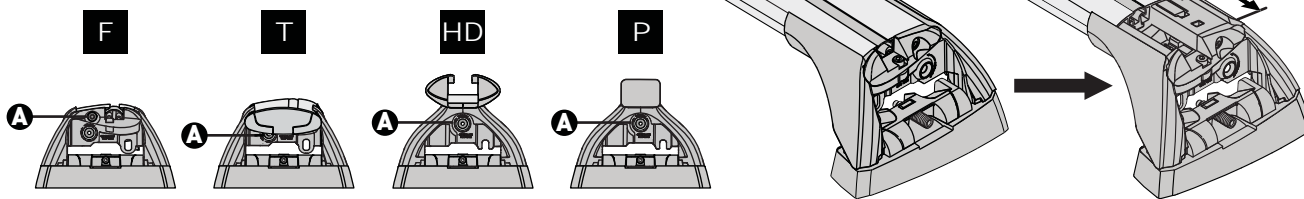

6

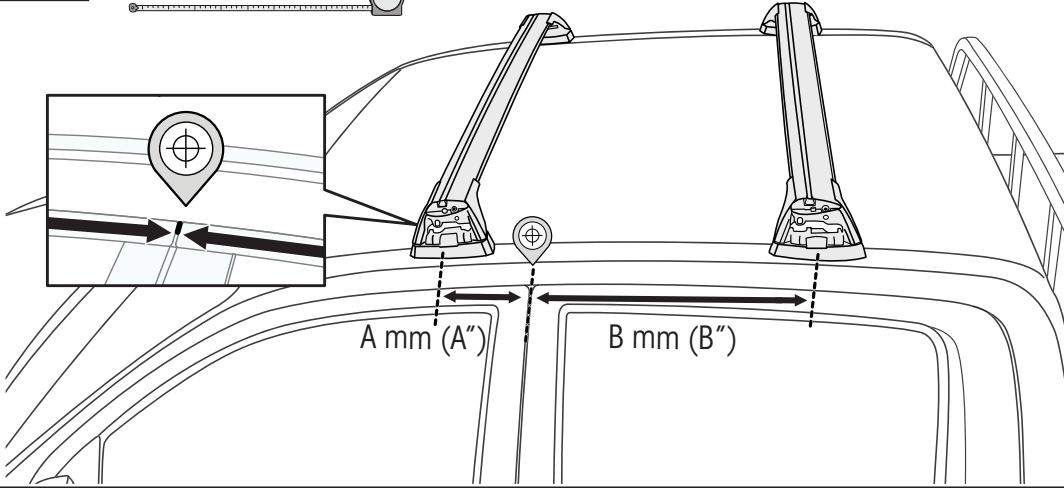
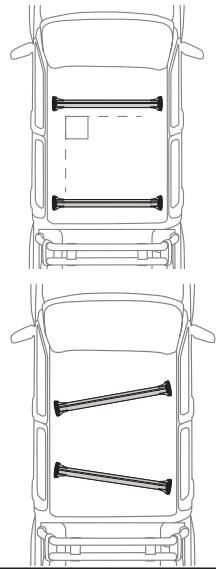
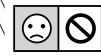

7

mm / inches

		-A	B
Nissan Navara D40 Double Cab, 4dr Ute 05+	CN, EU	-A = 180 mm (7 1/8")	B = 520 mm (20 1/2")
Nissan Navara D40 Double Cab, 4dr Ute Nov 05-May 15	AU	-A = 180 mm (7 1/8")	B = 520 mm (20 1/2")
Nissan Navara D40 Double Cab, 4dr Ute Dec 05-May 15	NZ	-A = 180 mm (7 1/8")	B = 520 mm (20 1/2")
Nissan Navara D40 KingCab, 4dr Ute 05+	EU	-A = 345 mm (13 5/8")	B = 355 mm (14")
Nissan Navara D40 KingCab, 4dr Ute 05-May 15	AU, NZ, ZA	-A = 345 mm (13 5/8")	B = 355 mm (14")
Nissan Navara D40 Single Cab, 2dr Ute 05-15	AU, NZ	-A = 180 mm (7 1/8")	-
Nissan Pathfinder, 5dr SUV 05+	CN, EU	-A = 230 mm (9")	B = 470 mm (18 1/2")

**PLACEMENT • PLATZIERUNG • COLOCACIÓN • MONTAGE • PLASSERING • COLOCAÇÃO • РАЗМЕЩЕНИЕ
MONTAGGIO • UMIESZCZENIE • UMÍSTĚNÍ • UMIESTNENIE • PLAATSING • PLACERING**



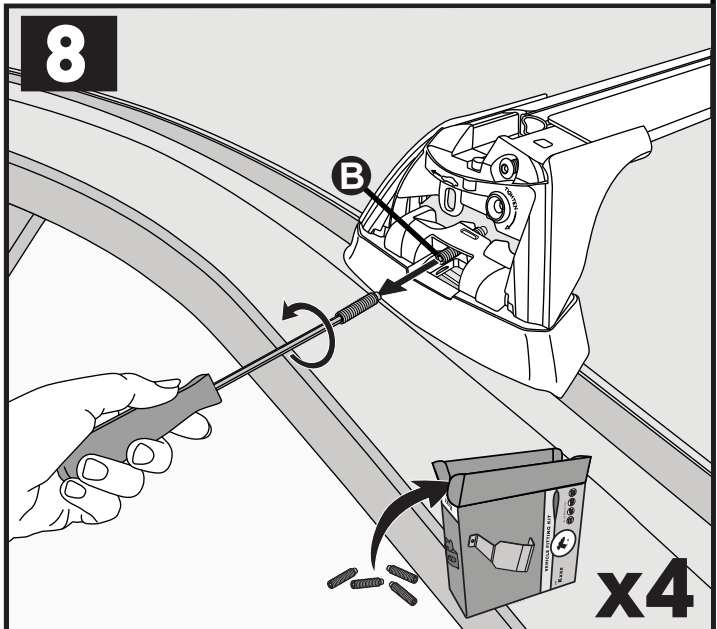
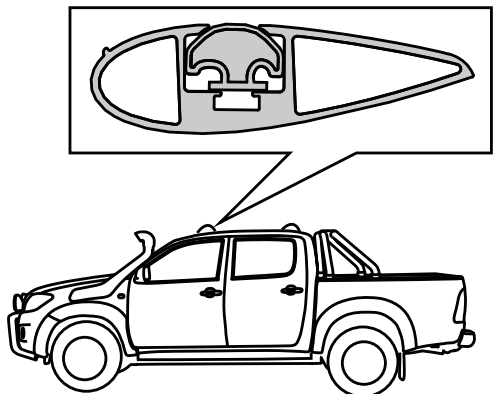
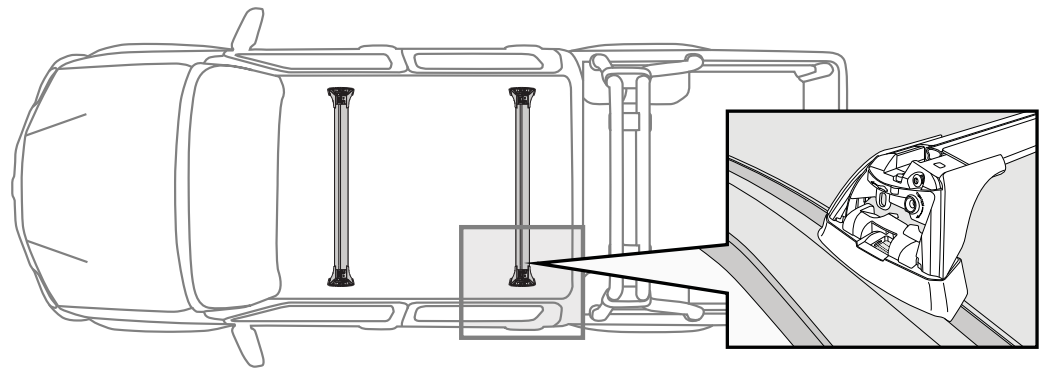

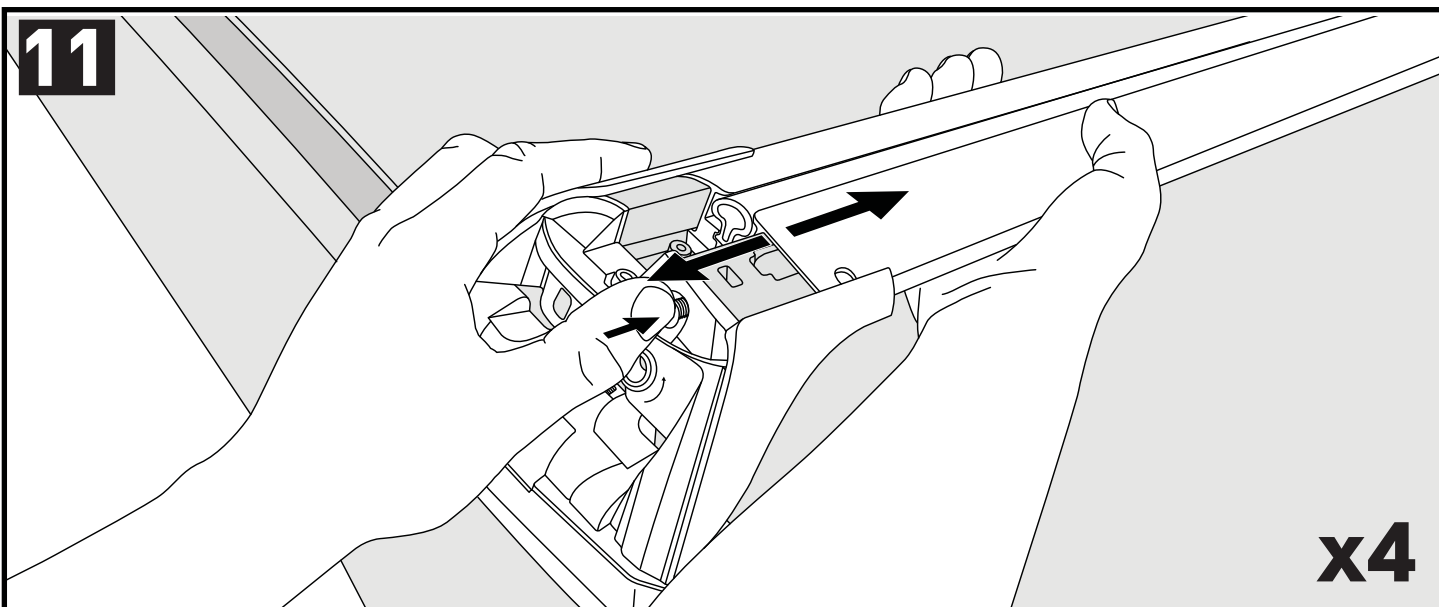
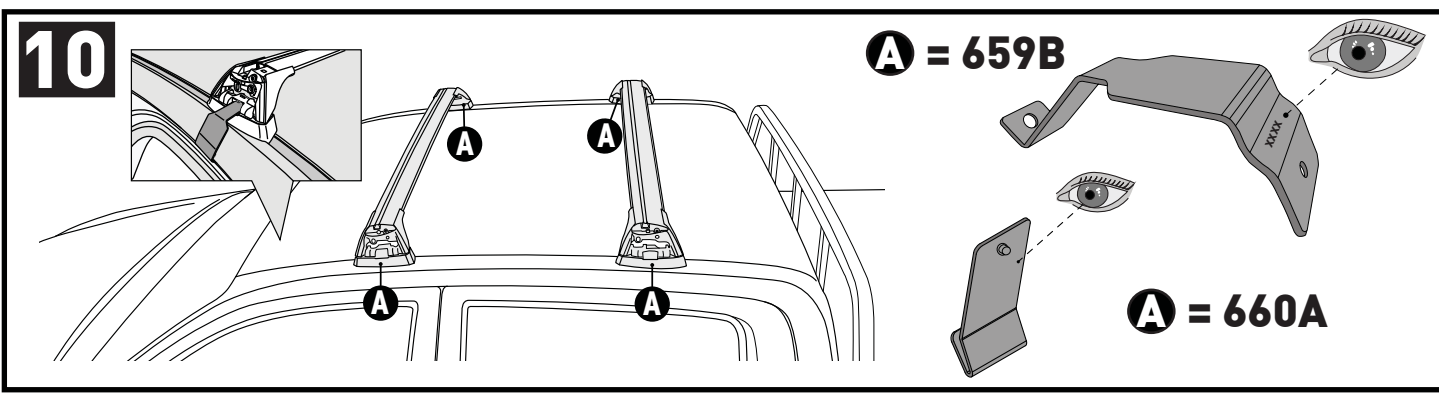
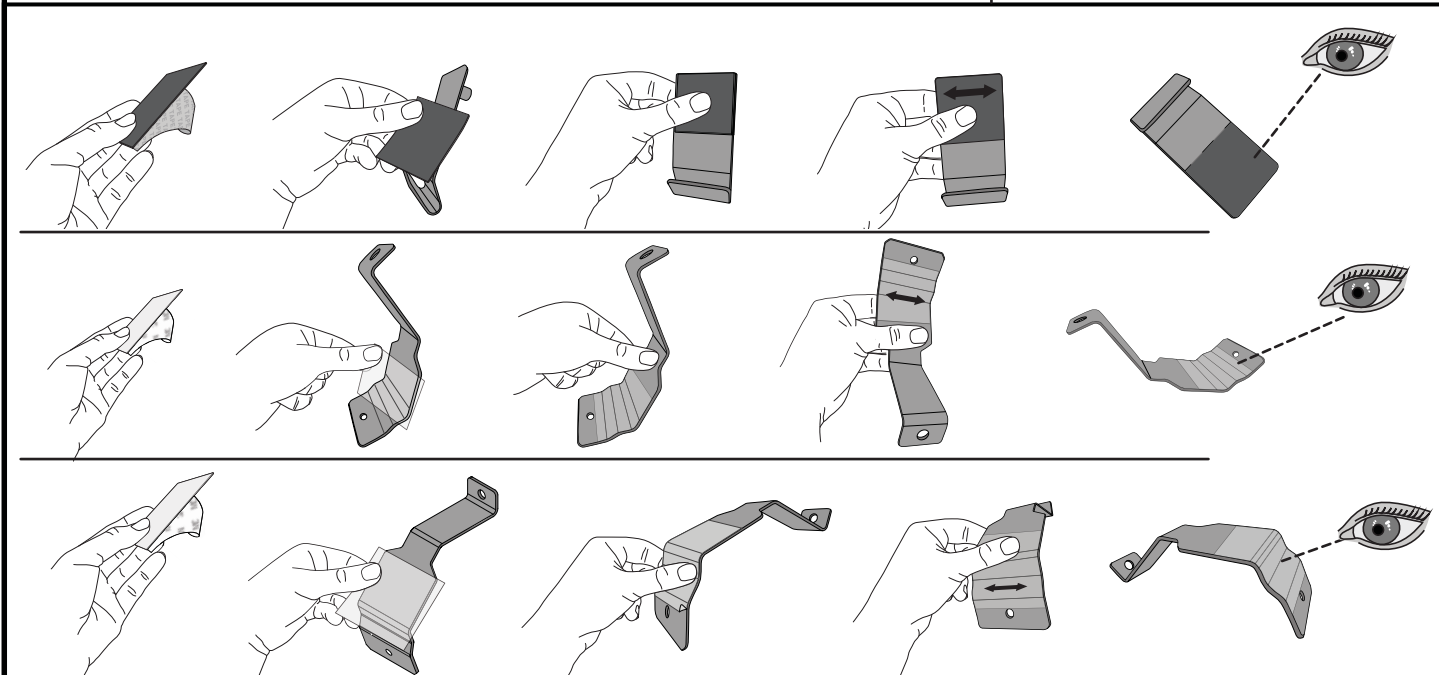
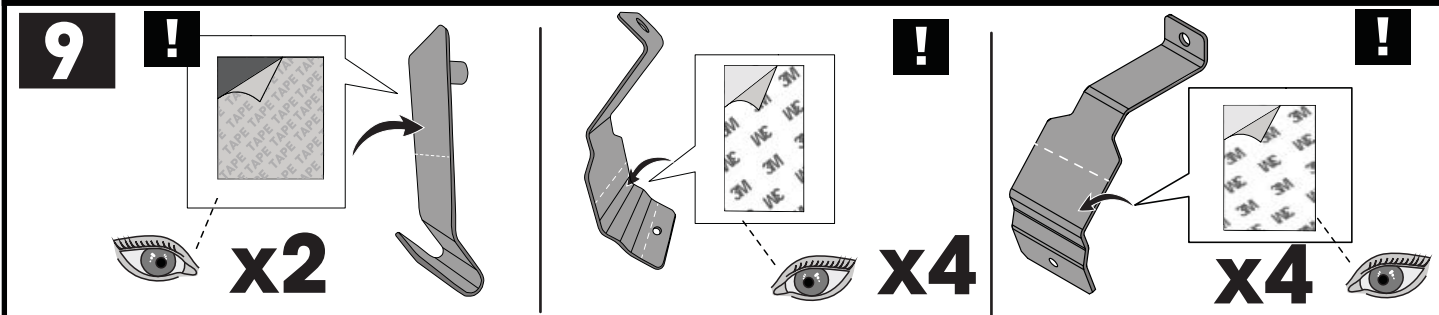
12

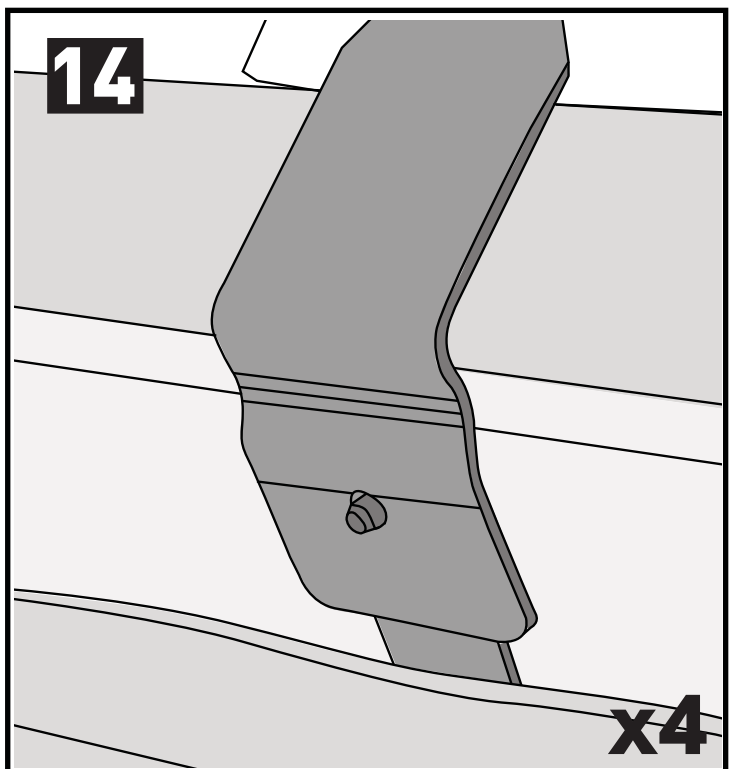
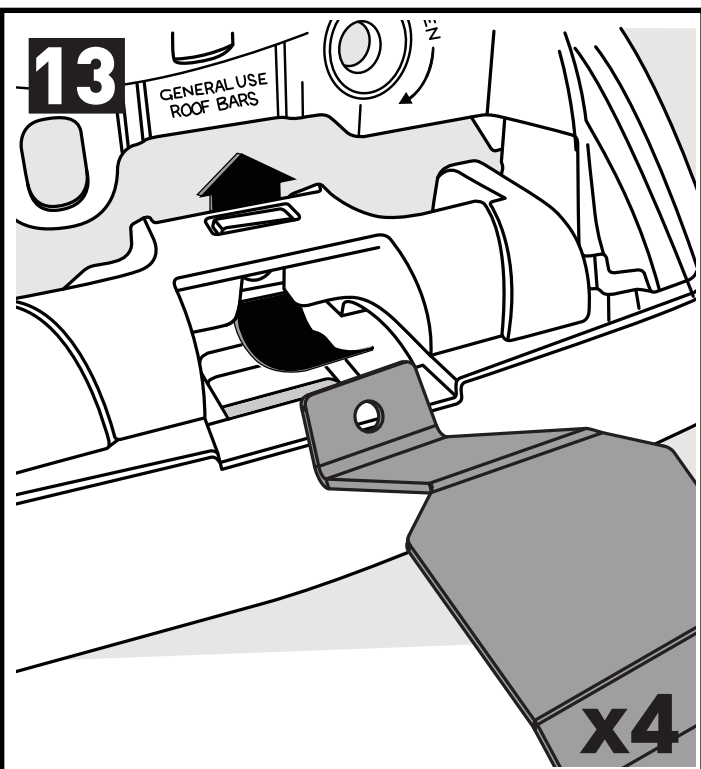
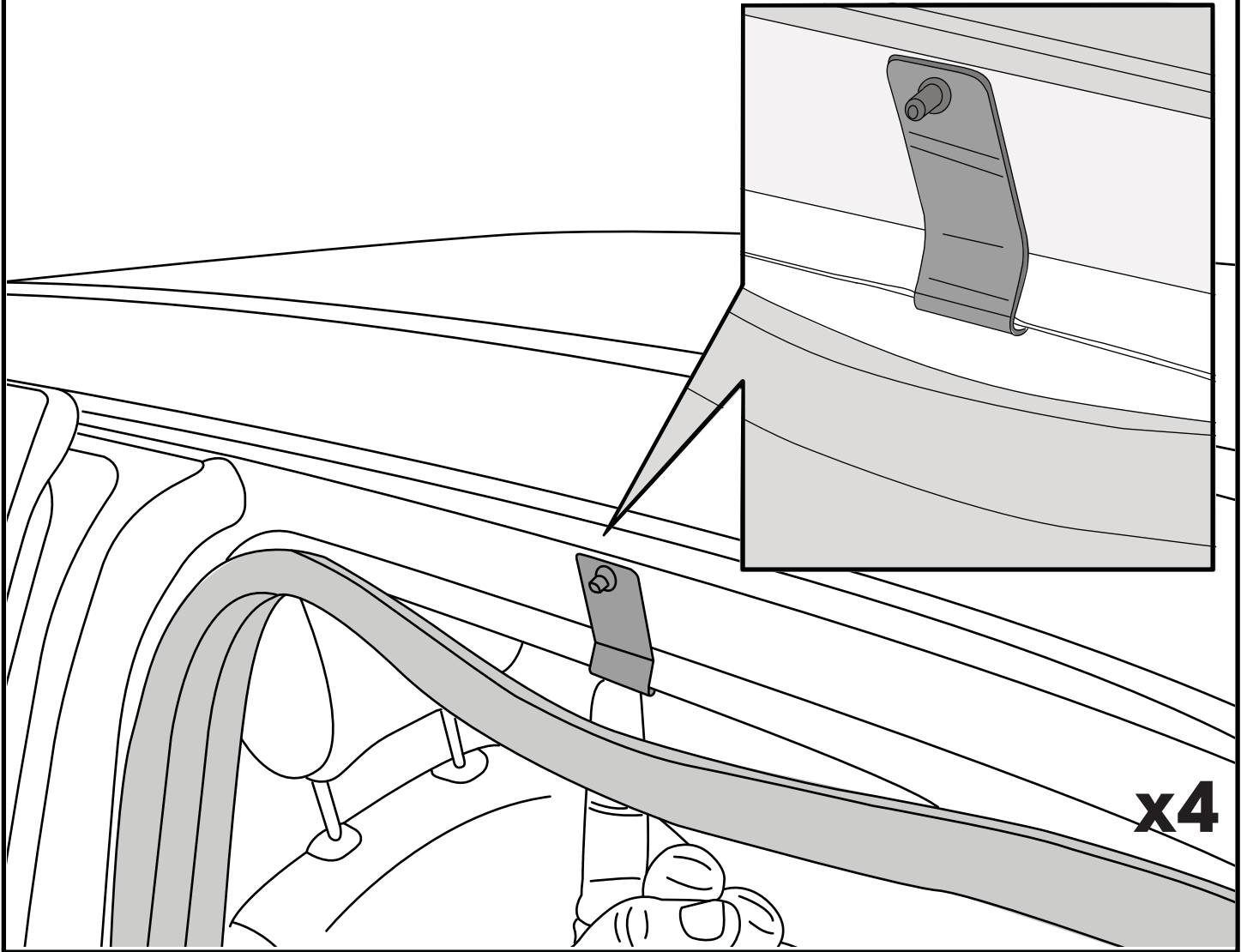

15

x3

B

x4

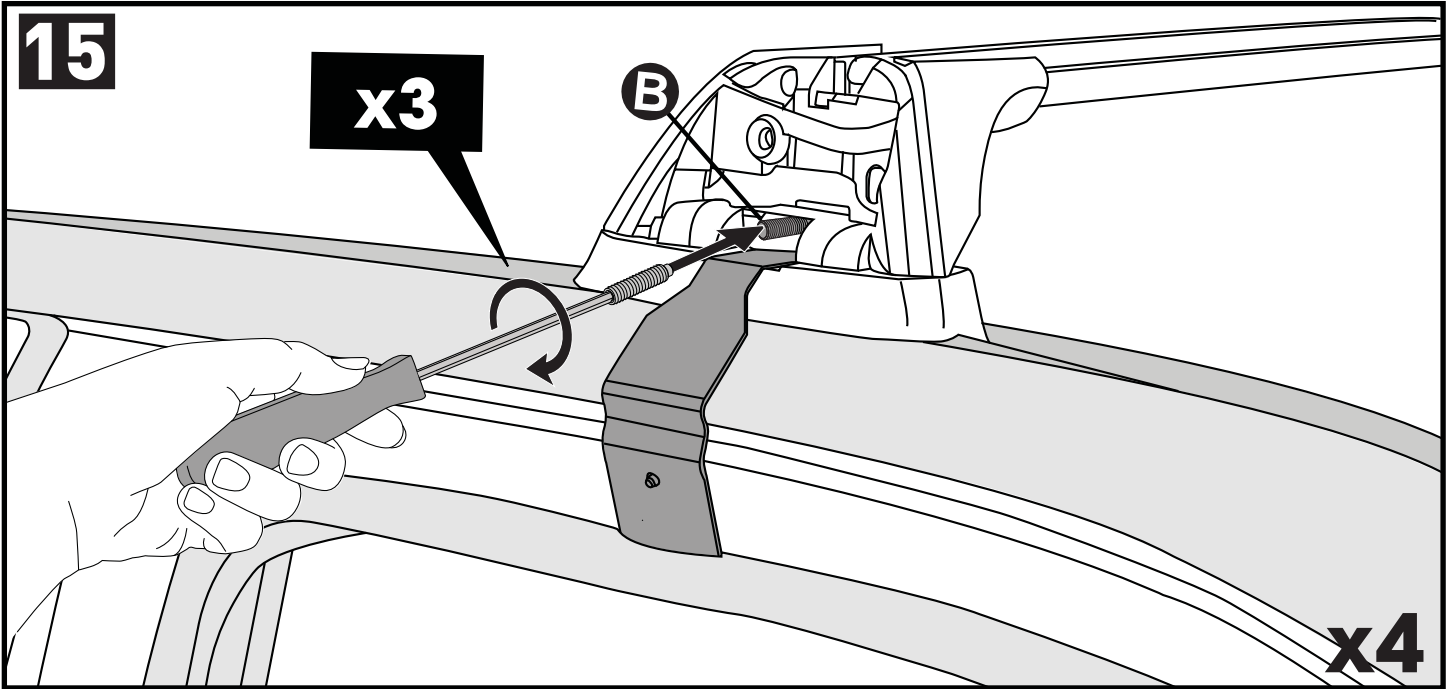

16

F

T

HD

P

A

A

A

A

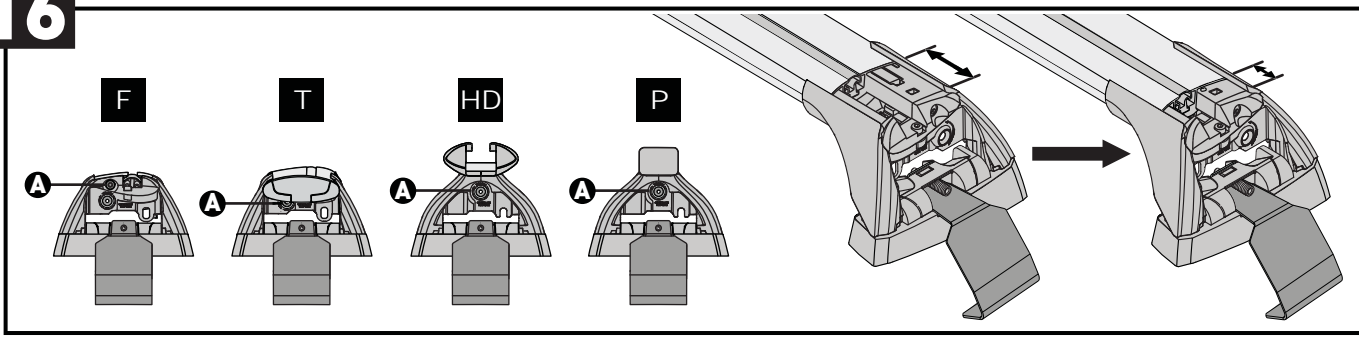

F

A

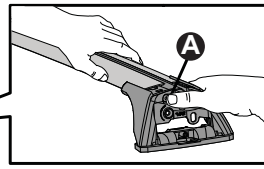
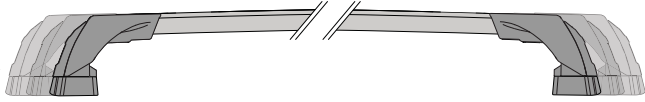
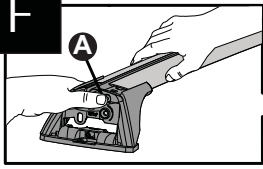

T

A

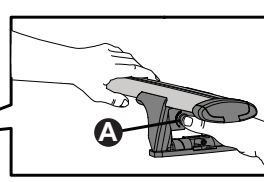
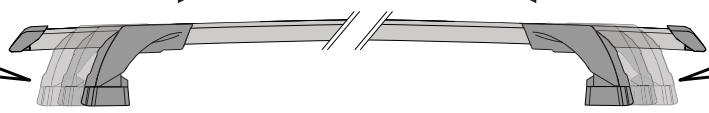
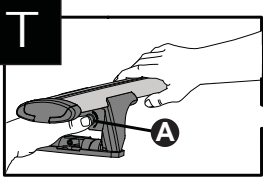

HD

A

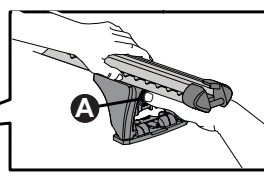
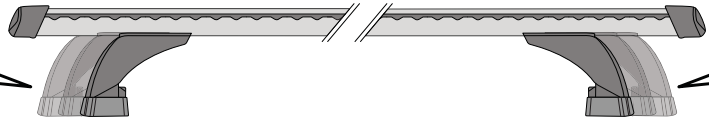
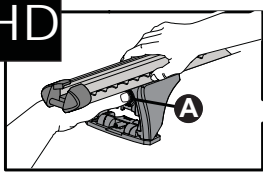

P

A

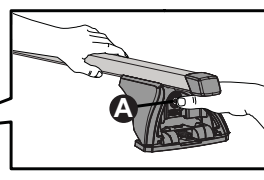
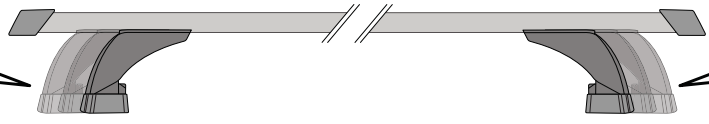
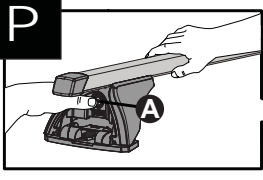

CLOSE • GESCHLOSSEN • CERRAR • FERMER • LUKKE • FECHAR • ЗАКРЫТЬ • SERRARE • BLISKO ZAVŘÍT • ZAVRIĚT • GESLOTEN • STÄNGA

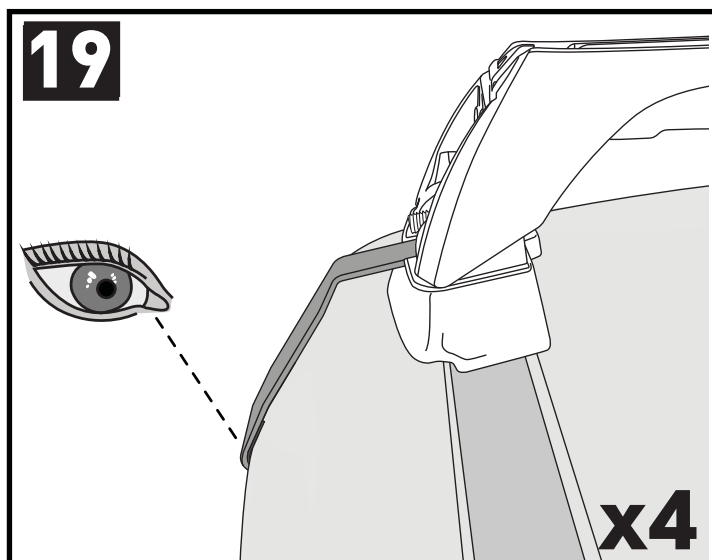
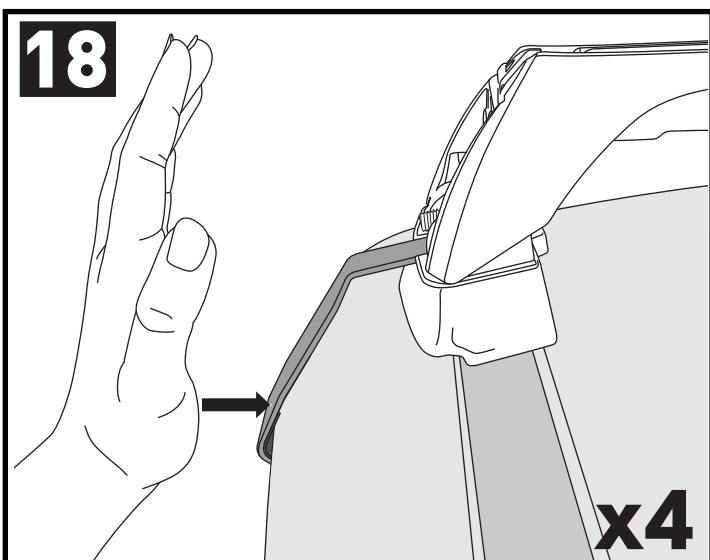
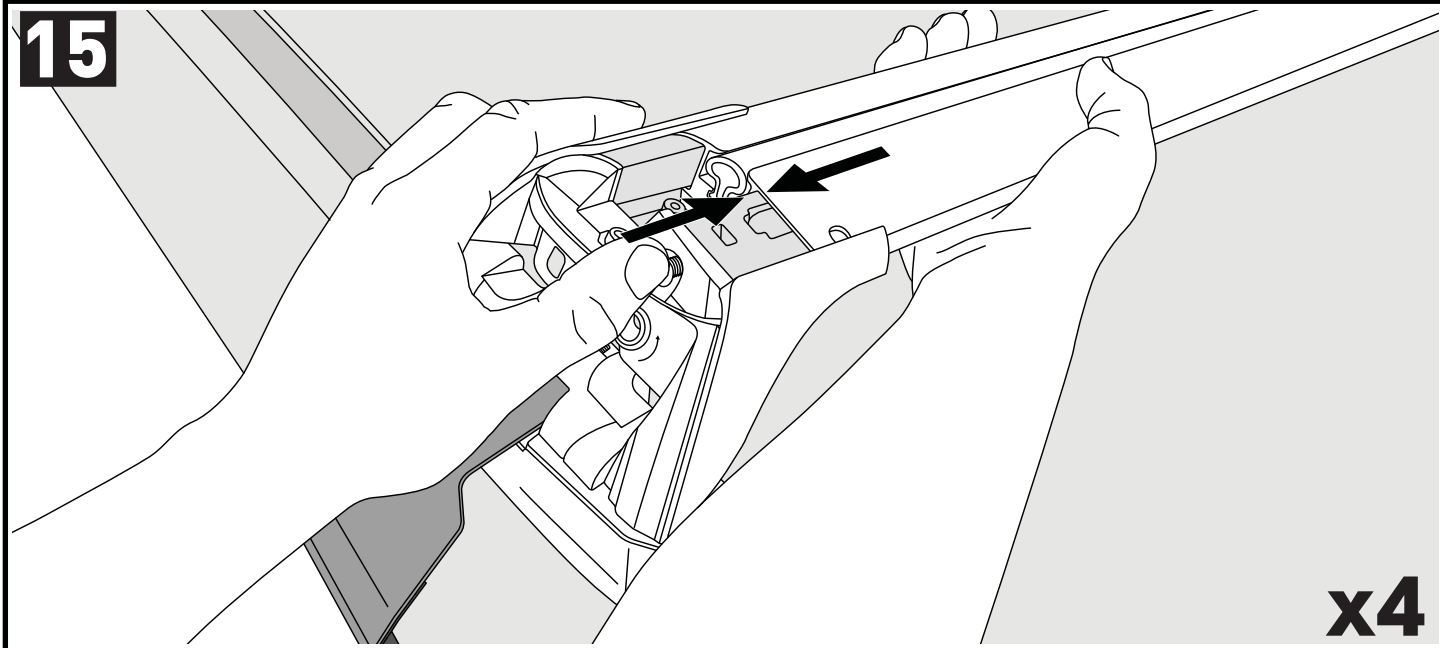

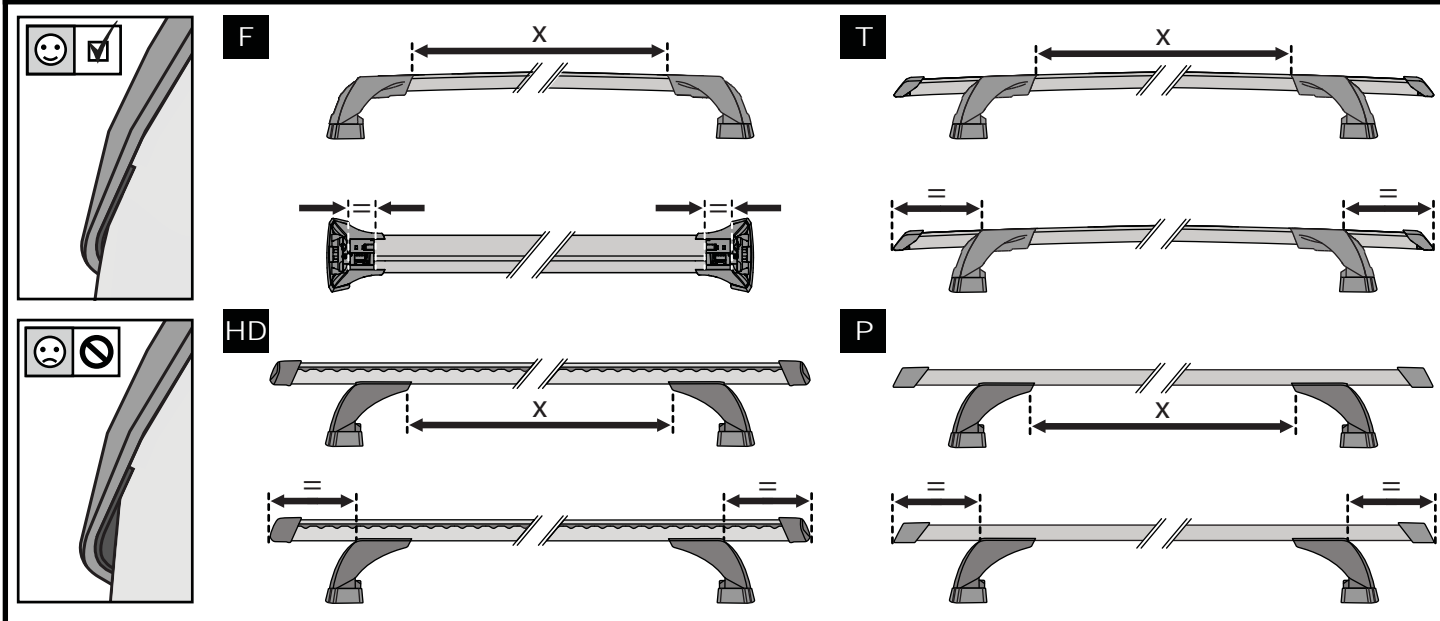

ATTENTION • ACHTUNG • ATENCIÓN • ATTENTION • OPPMERKSOMHET • ATENÇÃO • ВНИМАНИЕ
ATTENZIONE • UWAGA • UPOZORNĚNÍ • UPOZORNENIE • LET OP • UPPMÄRKSAMHET

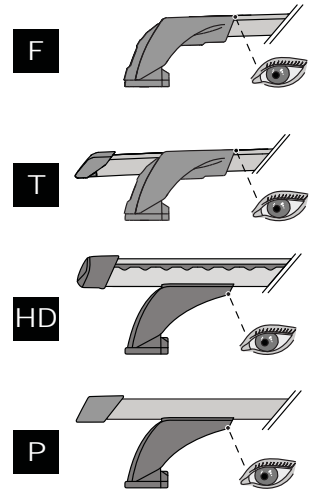
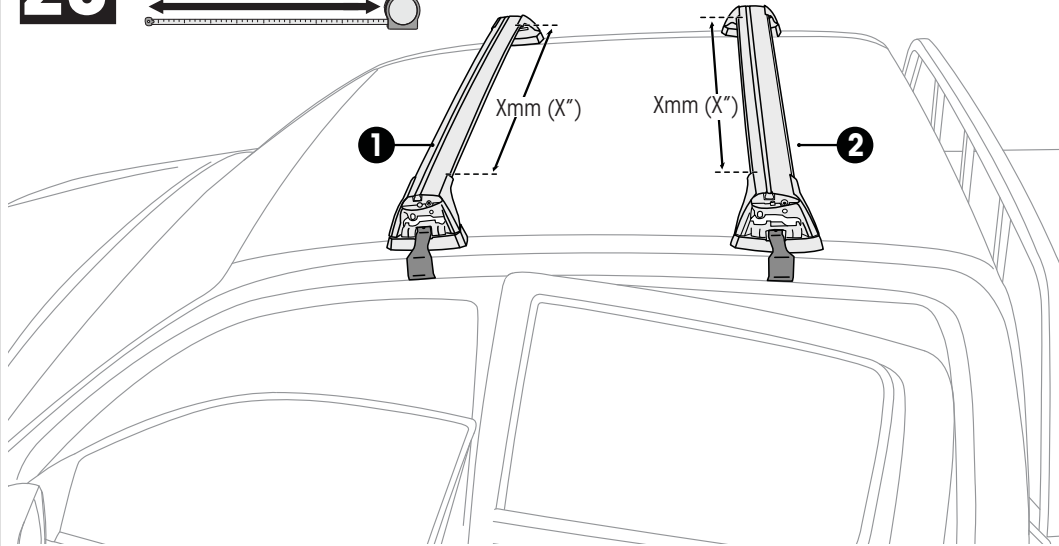

20

mm / inches



		1	2
Nissan Navara D40 Double Cab, 4dr Ute 05+	CN, EU	X = 970 mm (38 1/4")	X = 970 mm (38 1/4")
Nissan Navara D40 Double Cab, 4dr Ute Nov 05-May 15	AU	X = 970 mm (38 1/4")	X = 970 mm (38 1/4")
Nissan Navara D40 Double Cab, 4dr Ute Dec 05-May 15	NZ	X = 970 mm (38 1/4")	X = 970 mm (38 1/4")
Nissan Navara D40 KingCab, 4dr Ute 05+	EU	X = 960 mm (37 6/8")	X = 940 mm (37")
Nissan Navara D40 KingCab, 4dr Ute 05-May 15	AU, NZ, ZA	X = 960 mm (37 6/8")	X = 940 mm (37")
Nissan Navara D40 Single Cab, 2dr Ute 05-15	AU, NZ	X = 960 mm (37 6/8")	-
Nissan Pathfinder, 5dr SUV 05+	CN, EU	X = 995 mm (39 3/8")	x = 990 mm (39")

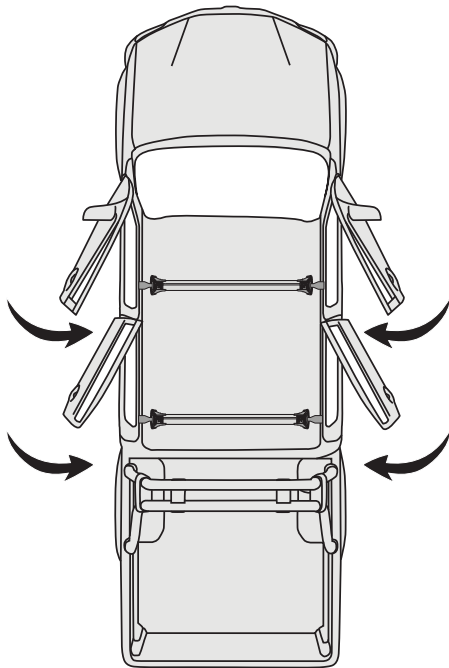

21



22



7 mm / inches

		A	B
Make Model, Variant, edr's V	File Type xx+	xxxx mm (xxx xxx")	xxxx mm (xxx xxx")
Make Model, Variant, edr's V	File Type xx+	xxxx mm (xxx xxx")	xxxx mm (xxx xxx")
Make Model, Variant, edr's V	File Type xx+	xxxx mm (xxx xxx")	xxxx mm (xxx xxx")

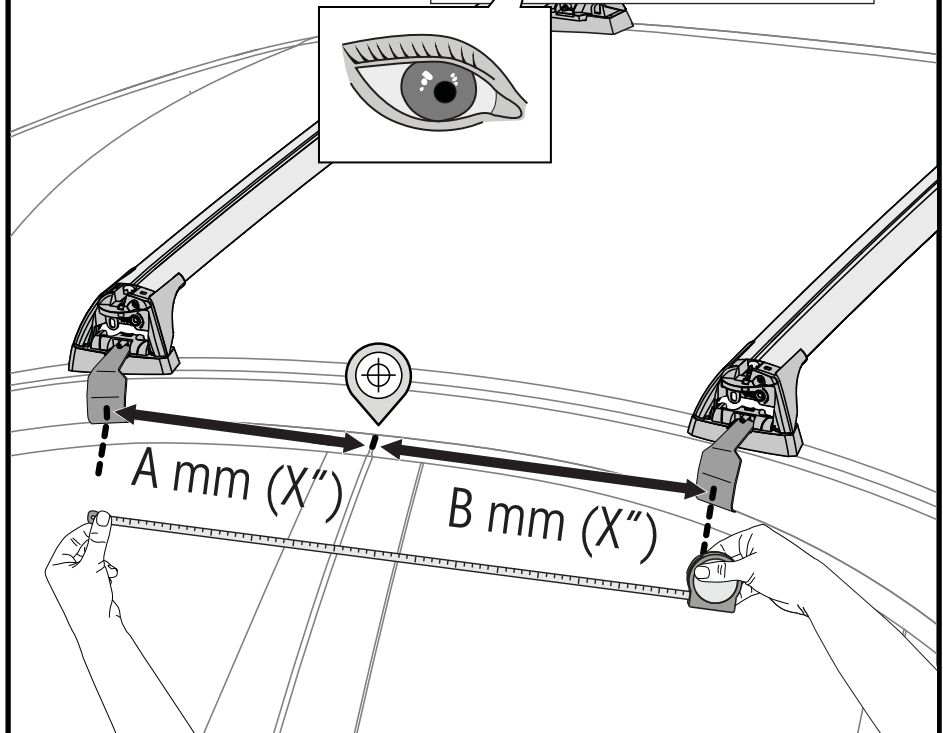

23

2 Nm
(18 lb-in)

A

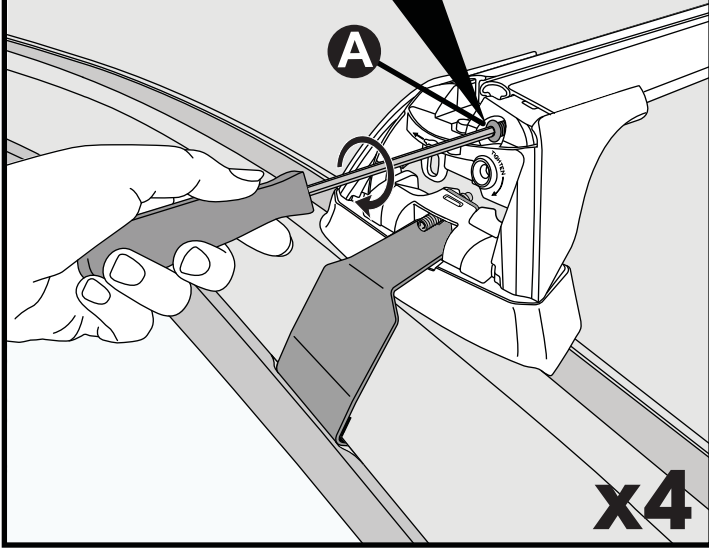

x4

24

2.5 Nm
(22 lb-in)

B

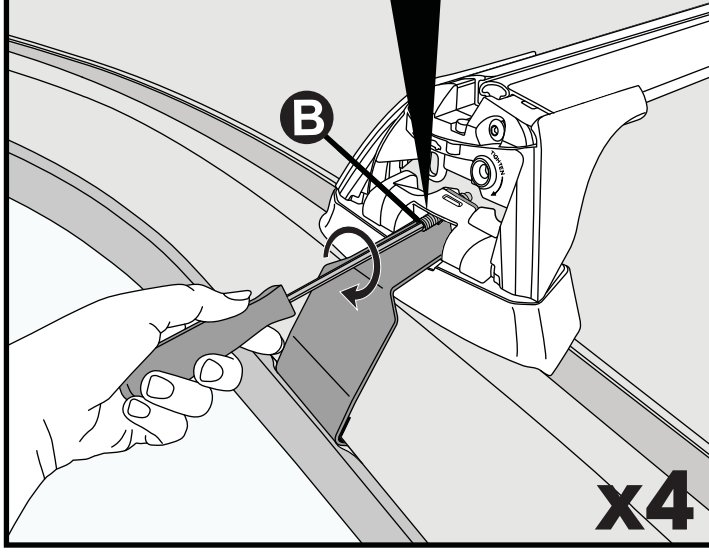

x4

25

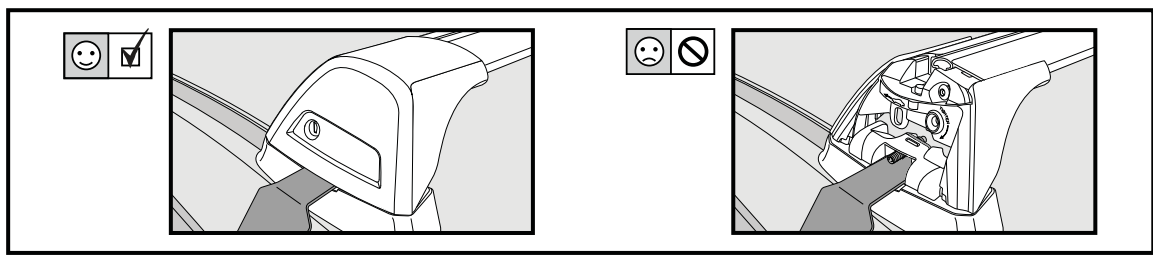
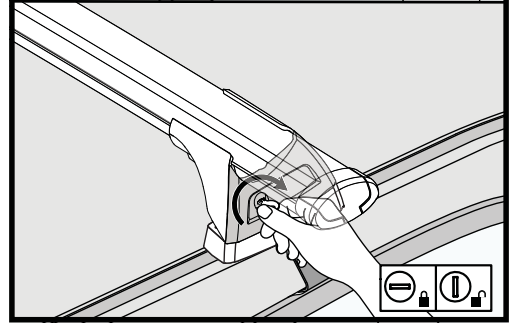
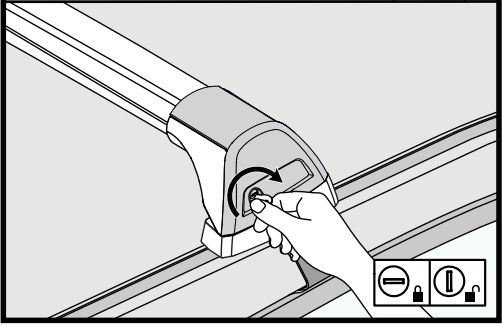
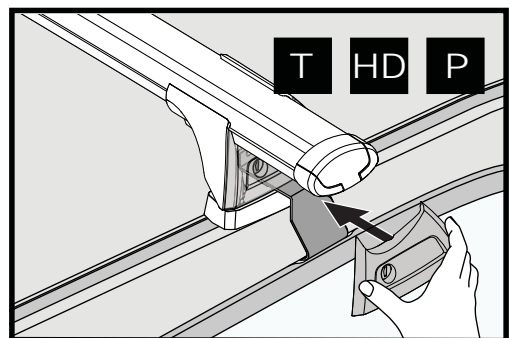
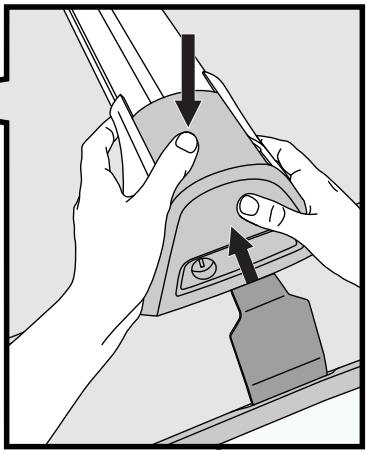
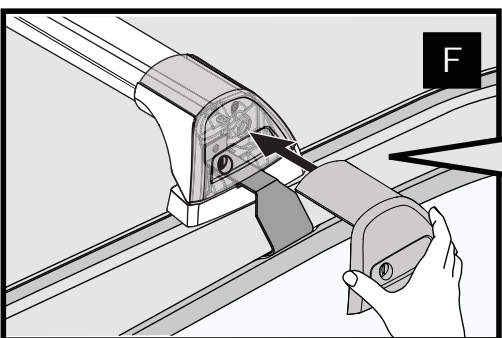

x4

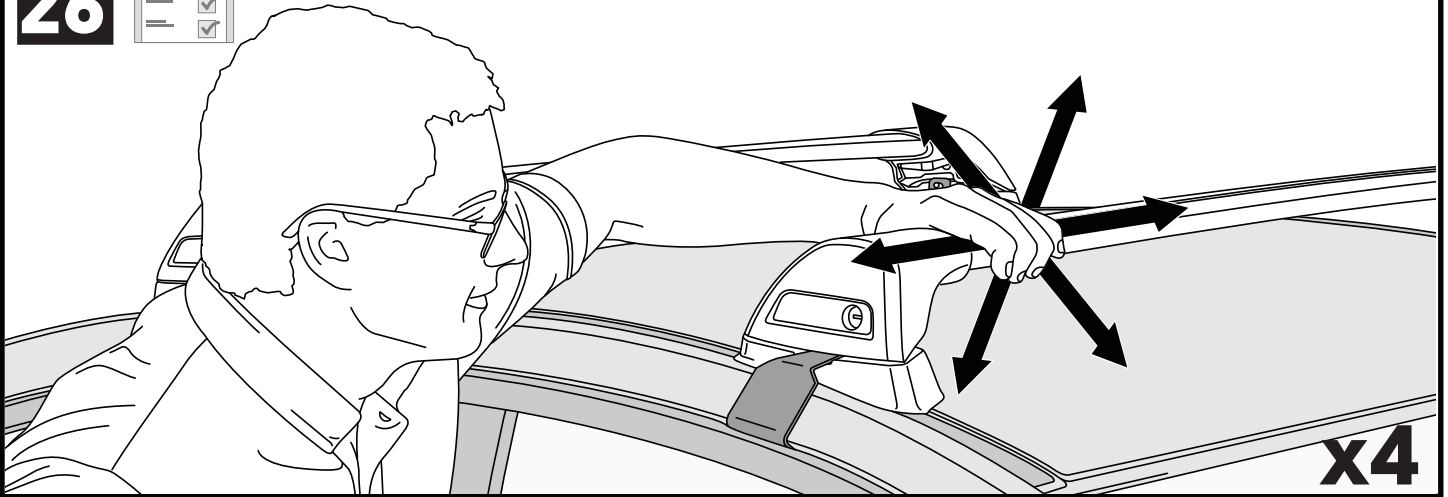
26**x4**

**ATTENTION • ACHTUNG • ATENCIÓN • ATTENTION • OPPMERKSOMHET • ATENÇÃO • ВНИМАНИЕ
ATTENZIONE • UWAGA • UPOZORNĚNÍ • UPOZORNENIE • LET OP • UPPMÄRSAMHET**

EN Please read safety and warranty booklet included with this product prior to use. For more information visit your local dealer.

DE Bitte lesen und beachten Sie die beiliegende Montageanleitung, Sicherheitshinweise und Garantiebedingungen bevor Sie das Produkt montieren/benutzen. Für weitere Informationen kontaktieren Sie bitte Ihren Händler.

ES Por favor, lea folleto de seguridad y garantía que se incluye con este producto antes de su uso. Para obtener más información, visite a su distribuidor local.

FR Veuillez lire attentivement le manuel de sécurité et de garantie avant utilisation. Pour plus d'informations, visitez votre concessionnaire local.

NO Vennligst les hefte om sikkerhet og garanti som er vedlagt dette produkt før det tas i bruk. For mer informasjon ta kontakt med din forhandler.

PT Por favor leia o manual de segurança e garantia incluído, antes de utilizar o produto. Para mais informações visite o seu revendedor local.

RU Пожалуйста, ознакомьтесь с инструкцией перед тем, как использовать товар. Для получения более подробной информации обратитесь к местному дилеру.

IT Si prega di leggere il libretto di sicurezza e garanzia incluso nel prodotto prima dell'uso. Per maggiori informazioni visita il rivenditore locale.

PL Proszę zapoznać się z warunkami gwarancji i bezpieczeństwa przed użyciem produktu. W celu uzyskania dodatkowych informacji proszę kontaktować się z najbliższym autoryzowanym punktem sprzedaży.

CS Před použitím si prosím přečtete přiložené informace o bezpečnosti a záručních podmínkách. Pro více informací navštivte nejbližšího dealera.

SK Pred použitím si prosím prečítajte priložené informácie o bezpečnosti a záručných podmienkach. Pre viac informácií navštívte najbližšieho dčlera.

NL A.U.B. bijgesloten garantie- en veiligheidsinstructies grondig lezen voor gebruik van dit product. Voor meer informatie graag contact opnemen met uw dealer.

SV Var snabb och läs igenom säkerhets- och garantihäftet som medföljer produkten före användning. För mer information besök din lokala återförsäljare.

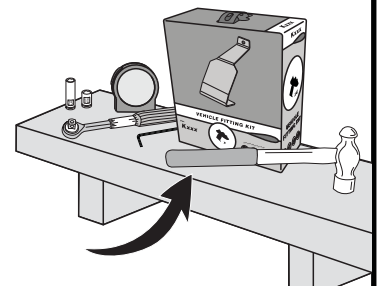
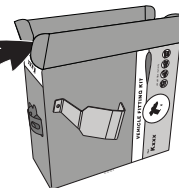
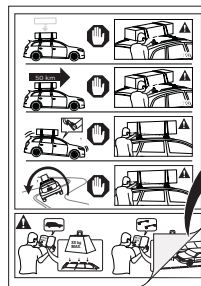
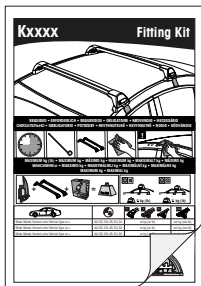
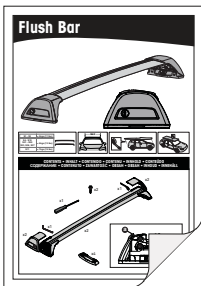
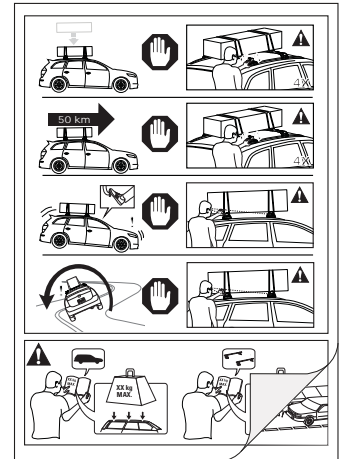

Yakima Australia Pty Ltd
17 Hinkler Court, Brendale
QLD 4500, Australia
1800 143 548
www.prorack.com.au
www.whispbar.com.au

Yakima Europe Coöperatief U.A.
Twentehaven 7, 3433
PT Nieuwegein, The Netherlands
+31 2080 81425
www.prorackeurope.eu
www.whispbar.eu

Yakima Products, Inc.
4101 Kruse Way
Lake Oswego, OR. 97035 USA
888 925 4621
www.whispbar.com